

Roll No.

Total No. of Pages : 03

Total No. of Questions : 09

B.Tech. (2011 to 2017) (Sem.-1,2)
ELEMENTS OF MECHANICAL ENGINEERING
Subject Code : BTME-101
M.Code : 54101

Time : 3 Hrs.

Max. Marks : 60

INSTRUCTIONS TO CANDIDATES :

1. SECTION-A is COMPULSORY consisting of TEN questions carrying TWO marks each.
2. SECTION - B & C have FOUR questions each.
3. Attempt any FIVE questions from SECTION B & C carrying EIGHT marks each.
4. Select atleast TWO questions from SECTION - B & C.

SECTION-A

1. Answer briefly :

- a) Distinguish between Intensive and Extensive properties.
- b) Distinguish between quasi static process and actual process.
- c) State Zeroth Law of Thermodynamics.
- d) Distinguish between internal energy and enthalpy.
- e) What are positive and negative work interactions?
- f) What is an air-standard efficiency?
- g) Explain Poission's ratio.
- h) Define weldability.
- i) Enumerate the criteria for selection of materials for engineering applications.
- j) Define polar moment of inertia.

SECTION-B

2. When a system is taken from 'a' to 'b' along the path 'acb', 400 kJ of heat flows into the system and the system does 100 kJ of work. Find
- How much heat flows into the system along the path 'adb' if the work done is 50 kJ?
 - If the system is brought from state 'b' to state 'a' along the curved path 'ba' and if the work done on the system is 100 kJ, find out the heat transfer of the system. Does it absorb or liberate heat?
 - If the value of internal energy $U_a = 0$ and $U_d = 200$ kJ find the heat transfer in the process ad and db.

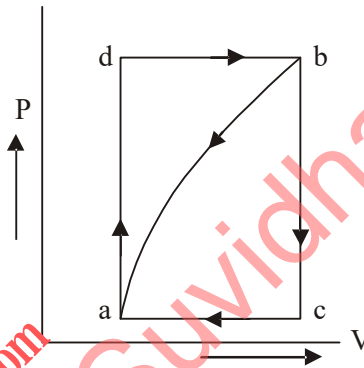

FIG.1

3. Derive steady flow energy equation for a single stream of fluid entering and leaving the control volume.
4. One mol of an ideal gas at 0.5 MPa and 300 K is heated at constant pressure till the volume is doubled and then it is allowed to expand reversibly and adiabatically till the temperature is reduced to 300 K. Calculate heat and work transfers. If it is desired to restore the system from final state to its initial state by a reversible isothermal process what amount of work is required to be done on the system?
5. Two reversible heat engines are arranged in series between temperatures 500°C and 0°C. The heat input from heat source at 500°C is 300 kJ. The work output of the first engine is twice of the second engine. Determine T_2 , Q_1 , Q_2 and Q_3 .

SECTION-C

6. An engine working on the Otto cycle is supplied with air at 1.1 MPa, 35°C. The compression ratio is 8. Heat supplied is 2100 kJ/kg. Calculate the maximum pressure and temperature of the cycle, the cycle efficiency, and the mean effective pressure. (For air, $c_p = 1.005$, $c_v = 0.718$, and $R = 0.287$ kJ/kg K).
7. Explain classification of Engineering materials. Explain characteristics of key engineering materials used in manufacturing.
8. Prove the parallel axis theorem in the determination of moment of inertia of areas with the help of a neat sketch.
9. Find the centre of gravity of I section shown in the figure.

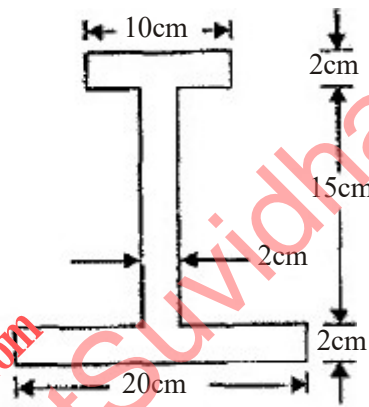

FIG.2

NOTE : Disclosure of Identity by writing Mobile No. or Making of passing request on any page of Answer Sheet will lead to UMC against the Student.